

hanskonner® HSG1801PRO

инструмент, в который верим

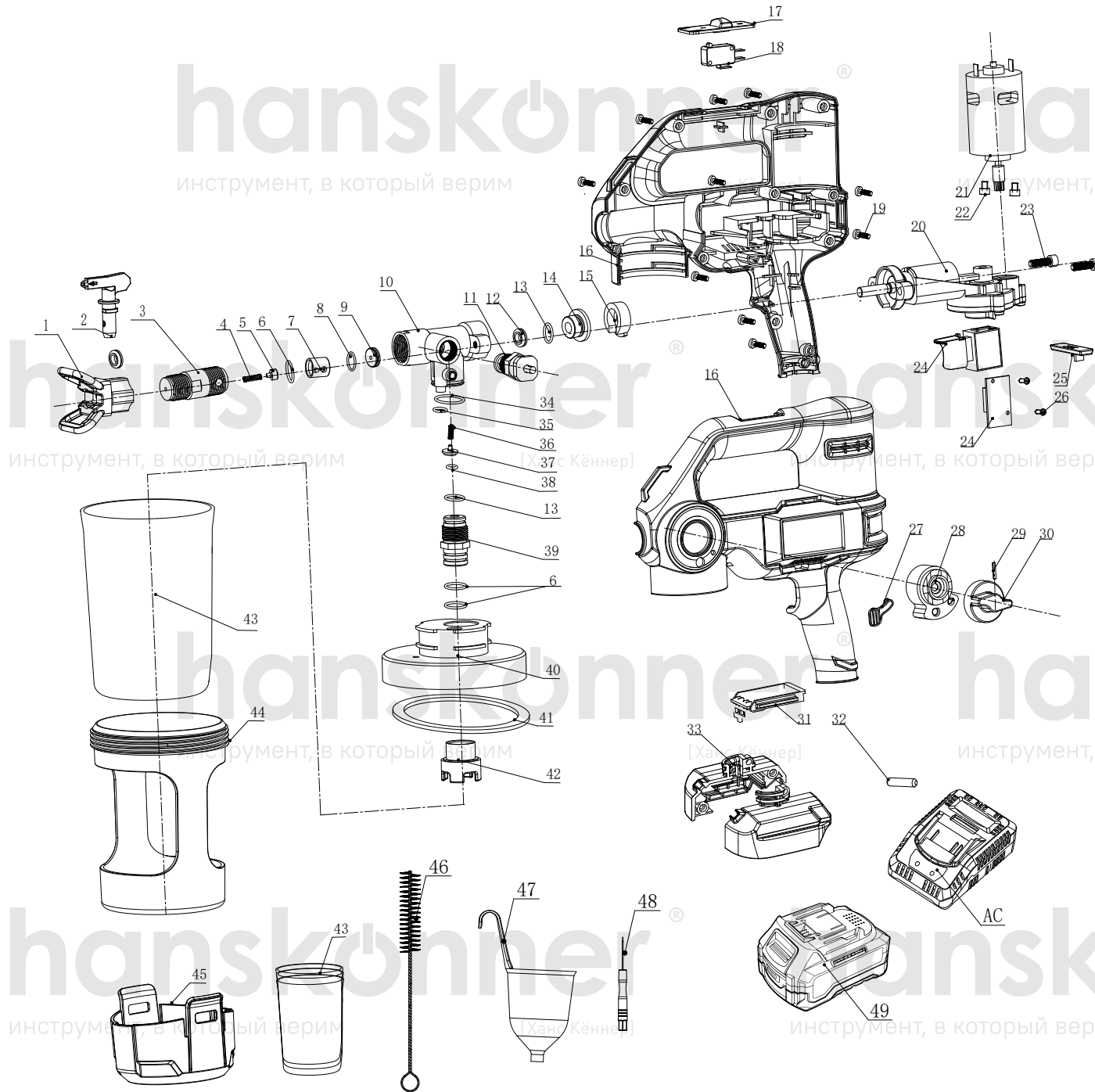

инструмент, в который верим

[Ханс Кённер]

инструмент, в который верим

инструмент, в который верим

[Ханс Кённер]

инструмент, в который верим

инструмент, в который верим

[Ханс Кённер]

инструмент, в который верим

HSG1801PRO

NO.	DESCRIPTION
1	SPRAY TIP SET
2	SPRAY TIP ASSEMBLY
3	EXTENSION SLEEVE ASSEMBLY
4	CHECK VALVE SPRING
5	DISCHARGE CHECK VALVE
6	O RING
7	LOCATING SLEEVE
8	O RING
9	LIQUID DISCHARGE VALVE ALLOY SHEET
10	PUMP ASSEMBLY
11	PRESSURE RELIEFVALVES ASSEMBLY
12	POLYMER COMPOSITE SEALING RING
13	O RING
14	LIMIT SLEEVE
15	LIMIT PAD
16	LEFT AND RIGHT HOUSING
17	SWITCH BUTTON
18	SWITCH
19	SCREW
20	REDUCTION GEARBOX ASSEMBLY
21	DC MOTOR ASSEMBLY
22	SCREW
23	SCREW
24	SWITCH&PCB ASSEMBLY
25	PUSHROD
26	SCREW
27	STOPPER
28	PRESSURE RELIEF VALVE SEAT
29	ELASTIC LOCKING PIN
30	PRESSURE RELIEF VALVE KNOB
31	BATTERY CLIP
32	ROUND PIN
33	LEFT AND RIGHT BATTERY FOOT
34	O RING
35	O RING
36	FEED VALVE SPRING
37	FEED VALVE
38	O RING
39	FEED VALVE SET
40	KETTLE SET
41	O RING
42	FILTER
43	SOFT CUP
44	KETTLE SET
45	PILLAR FOR RAISING HEIGHT
46	CLEANING BRUSH
47	VISCOSITY MEASURING CUP
48	CLEANING NEEDLE
49	BATTERY PACK
AC	CHARGER

HSG1801PRO-EX-RU250916-1

инструмент, в который верим

[Ханс Кённер]

инструмент, в который верим

[Ханс Кённер]